

### Specifications

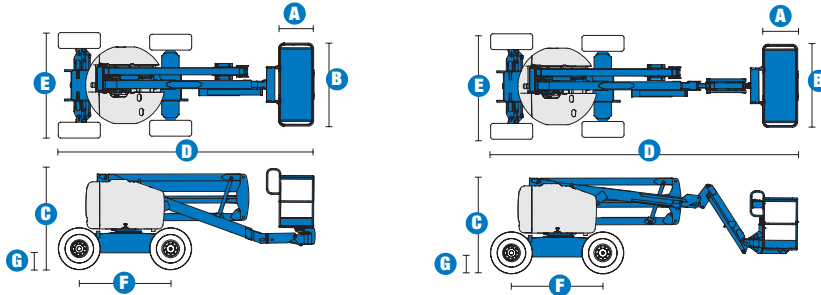

MODELS	Z™-45/25 RT		Z™-45/25J RT	
MEASUREMENTS	Metric	US	Metric	US
Working height maximum*	16 m	51 ft 11 in	16.07 m	52 ft 2 in
Platform height maximum*	14 m	45 ft 11 in	14.07 m	46 ft 2 in
Horizontal reach maximum*	7.62 m	25 ft	7.65 m	25 ft 1 in
Up-and-over clearance maximum	7.16 m	23 ft 6 in	7.37 m	24 ft 2 in
A Platform length	76 cm	2 ft 6 in	76 cm	2 ft 6 in
B Platform width	1.83 m	6 ft	1.83 m	6 ft
C Height - stowed	2.11 m	6 ft 11 in	2.11 m	6 ft 11 in
D Length - stowed	5.56 m	18 ft 3 in	6.83 m	22 ft 5 in
E Width	2.29 m	7 ft 6 in	2.29 m	7 ft 6 in
F Wheelbase	2.03 m	6 ft 8 in	2.03 m	6 ft 8 in
G Ground clearance - centre	39.4 cm	1 ft 3.5 in	39 cm	1 ft 3.5 in

PRODUCTIVITY				
Lift capacity	227 kg	500 lbs	227 kg	500 lbs
Platform rotation	180°	180°	160°	160°
Vertical jib rotation	-	-	135° (+78°/-57°)	135°
Turntable rotation	355° non-continuous	355° non-continuous	355° non-continuous	355° non-continuous
Turntable tailswing	zero	zero	zero	zero
Drive speed - stowed	8 km/h	5 mph	8 km/h	5 mph
Drive speed - raised **	30 cm/s	1ft/s	30 cm/s	1ft/s
Gradeability - 2WD - stowed***	30%	30%	30%	30%
Gradeability - 4WD - stowed***	45%	45%	45%	45%
Turning radius - inside	1.70 m	5 ft 6 in	1.70 m	5 ft 6 in
Turning radius - outside	4.5 m	14 ft 9 in	4.5 m	14 ft 9 in
Controls	12 V DC proportional	12 V DC proportional	12 V DC proportional	12 V DC proportional
Tyres	355/55 D625	355/55 D625	355/55 D625	355/55 D625

POWER				
Power source	Ford DSG-423 4 cylinder petrol/LPG 75 hp (56 kW) Deutz diesel D 2011 L03i 3 cylinder diesel 48 hp (35.8 kW) Perkins diesel 404D-22 4-cylinder diesel 51 hp (38 kW)			
Auxiliary power unit	12 V DC	12 V DC	12 V DC	12 V DC
Hydraulic tank capacity	90.8 L	24 gal	90.8 L	24 gal
Fuel tank capacity	64.4 L	17 gal	64.4 L	17 gal

SOUND & VIBRATION LEVELS				
Sound pressure level (ground workstation)	87 dBA	87 dBA	87 dBA	87 dBA
Sound pressure level (platform workstation)	82 dBA	82 dBA	82 dBA	82 dBA
Vibration	<2.5 m/s <sup>2</sup>	<8 ft 2 in/s <sup>2</sup>	<2.5 m/s <sup>2</sup>	<8 ft 2 in/s <sup>2</sup>

WEIGHT****				
CE 2WD (air tyres)	6,203 kg	13,675 lbs	6,486 kg	14,300 lbs
CE 4WD (air tyres)	6,294 kg	13,875 lbs	6,577 kg	14,500 lbs
CE 2WD (foam filled tyres)	6,550 kg	14,440 lbs	6,833 kg	15,064 lbs
CE 4WD (foam filled tyres)	6,641 kg	14,639 lbs	6,924 kg	15,265 lbs

#### STANDARDS COMPLIANCE

- EU Machinery Directive 2006/42/EC
- EU Standard EN280:2001, A2:2009
- EMC Directive 2004/108/EC EN 61000-6-2, EN 61000-6-4
- EU Noise Directive 2000/14/EC EN ISO 3744

\* The metric equivalent of working height adds 2 m to platform height. U.S. adds 6 ft to platform height.  
 \*\* In lift mode (platform raised), the machine is designed to operate on firm, level surfaces only.  
 \*\*\* Gradeability applies to driving on slopes. See Operator's Manual for details regarding slope ratings.  
 \*\*\*\* Weight will vary depending on options and/or country standards.

#### RANGE OF MOTION Z™-45/25 RT

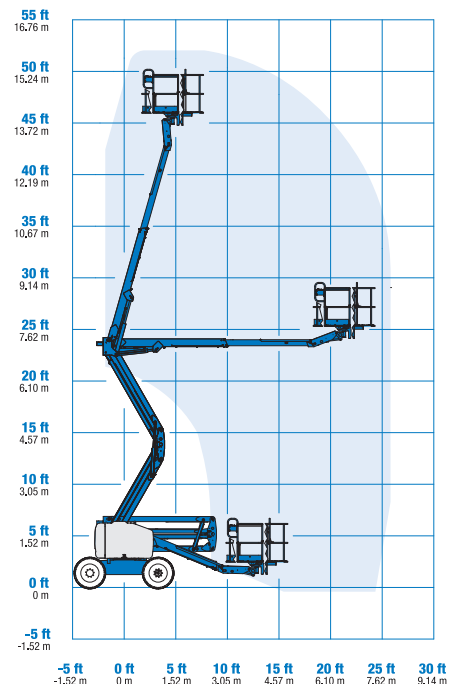

#### RANGE OF MOTION Z™-45/25J RT

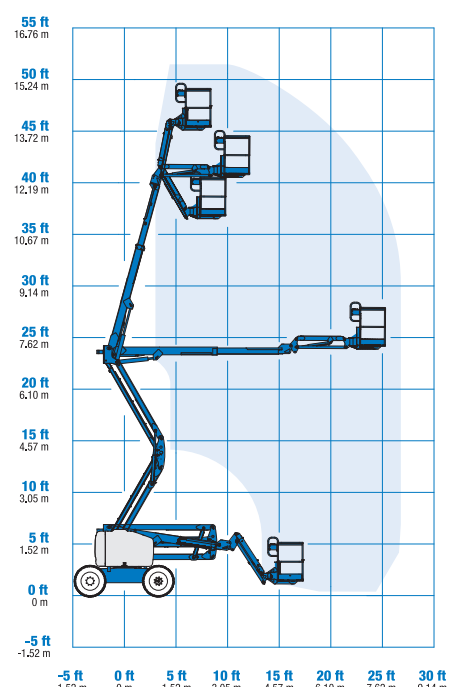

## Features

### EASILY CONFIGURED TO MEET YOUR NEEDS

#### PLATFORM OPTIONS

- Steel 1.83 m (6 ft) (standard)
- 1.83 m (6 ft) tri-entry steel platform (option)

#### JIB OPTIONS

- Non-jib
- 1.52 m (5 ft) jib boom

#### POWER

- Deutz Diesel 48 hp (35.8 kW)
- Ford petrol/LPG 75 hp (56 kW)
- Perkins diesel 51 hp (38 kW)

#### DRIVE OPTIONS

- 2 x 4
- 4 x 4

#### AXLE OPTIONS

- Oscillating (standard on 4WD)
- Non-oscillating

#### TYRE OPTIONS

- Rough terrain air-filled (standard)
- Rough terrain foam-filled
- Rough terrain non-marking (air or foam-filled)

### STANDARD FEATURES

#### MEASUREMENTS

##### Z™-45/25 RT

- 16 m (51 ft 11 in) working height
- 7.62 m (25 ft) horizontal reach
- 7.16 m (24 ft 2 in) up-and-over clearance
- Up to 227 kg (500 lb) lift capacity

##### Z™-45/25J RT

- 16.07 m (52 ft 2 in) working height
- 7.65 m (25 ft 1 in) horizontal reach
- 7.37 m (23 ft 6 in) up-and-over clearance
- Up to 227 kg (500 lb) lift capacity

#### PRODUCTIVITY

- Self-levelling platform
- Hydraulic platform rotation
- Fully proportional controls
- Thumb rocker steer
- Drive enable
- AC power cord to platform
- Horn
- Hour meter
- Tilt alarm
- Descent alarm
- Alarm package (flashing beacon & travel alarm)
- 355° non-continuous turntable rotation
- Positive traction drive
- Two-speed wheel motors
- Certified load sensor

#### POWER

- All engines are emission compliant
- 12 V DC auxiliary power
- Engine protection package
- Deutz intake air heater
- Swing-out engine tray



### OPTIONS & ACCESSORIES

#### PRODUCTIVITY

- Platform swing gate
- Half-mesh platform inserts with swing gate
- Platform top auxiliary rail
- Air line to platform
- Power to platform (incl. plug, socket and ground fault interrupt leakage on request)
- Light package: 2 chassis mounted drive lights, 2 platform mounted work lights
- Hostile environment kit: cylinder bellows, boom wiper seals, platform control box cover
- Low temperature cut-out module
- Biodegradable hydraulic oil
- Aircraft protection kit: platform foam padding & padded disable system\*\*
- Tool tray
- Dual axis joystick steering
- Fluorescent tube caddy\*
- Panel cradle package\*\*\*
- Platform work lights
- Lockable platform control box cover
- Tow package

#### POWER

- Engine gauge package (oil pressure, temp & amp)
- Engine heater
- AC generator packages (110V/60Hz or 220V/50Hz)
- Cold weather package
- Refinery kit (spark arrestor and electric or mechanical Chalwyn valve)
- LPG tank 15.19 kg (33.5 lb) capacity (Ford engine only)

\* Available aftermarket only

\*\* ZTM-45/25 J only, reduces platform capacity to 200 kg (440 lbs)

\*\*\* Requires tri-entry platform and foam filled tyres

#### Enquiries from Europe:

Tel: +31 165 519 361

Fax: +31 165 511 148

Email: AWP-InfoEurope@terex.com

#### Offices:

##### France

Tel: +33 (0)2 37 26 09 99

Fax: +33 (0)2 37 26 09 98

##### Germany

Tel: +49 (0)4221 491 810

Fax: +49 (0)4221 491 820

##### Spain

Tel: +34 93 572 50 90

Fax: +34 93 572 50 91

##### Scandinavia

Tel: +46 31 57 51 00

Fax: +46 31 57 51 04

##### The Netherlands

Tel: +31 165 519 361

Fax: +31 165 511 148

##### UK

The Maltings

Wharf Road

Grantham NG31 6BH

UK

Tel: +44 (0)1476 584333

Fax: +44 (0)1476 584334

##### Middle East

Tel: +971 4 399 0381

Fax: +971 4 399 0382

Email: AWP.Infome@terex.com

##### Russia & CIS countries

Tel: +7 495 660 32 30

Fax: +7 495 660 32 29

Email: info@terexrus.ru

#### Corporate Headquarters:

##### United States

18340 NE 76th Street

P.O. Box 97030

Redmond, WA

USA 98073-9730

Tel: +1 425 881-1800

Fax: +1 425 883-3475

#### Distributed By: